

**PLAN VIEW**

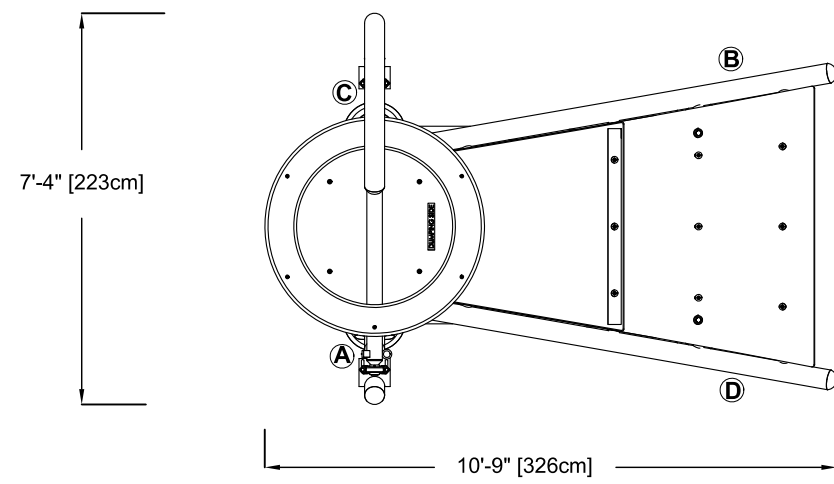

**ANCHORING LOCATIONS**

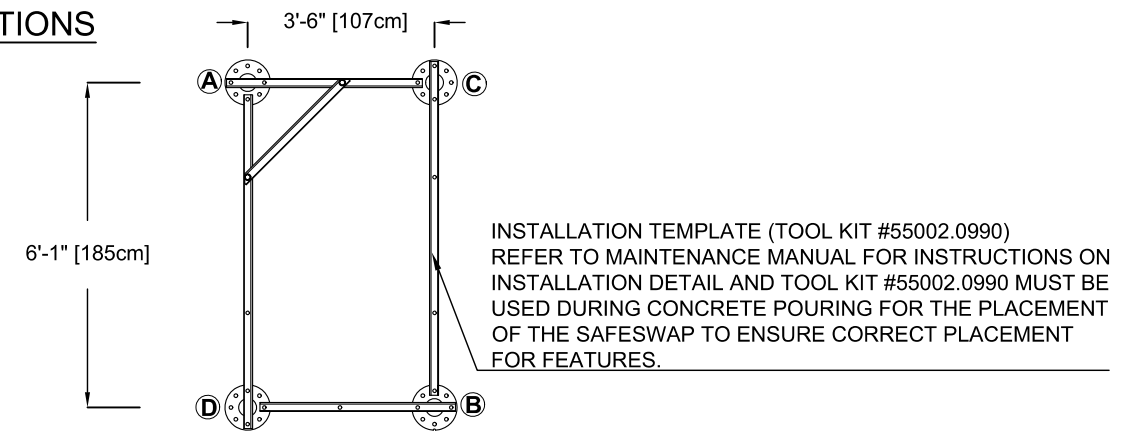

**FRONT ELEVATION VIEW**

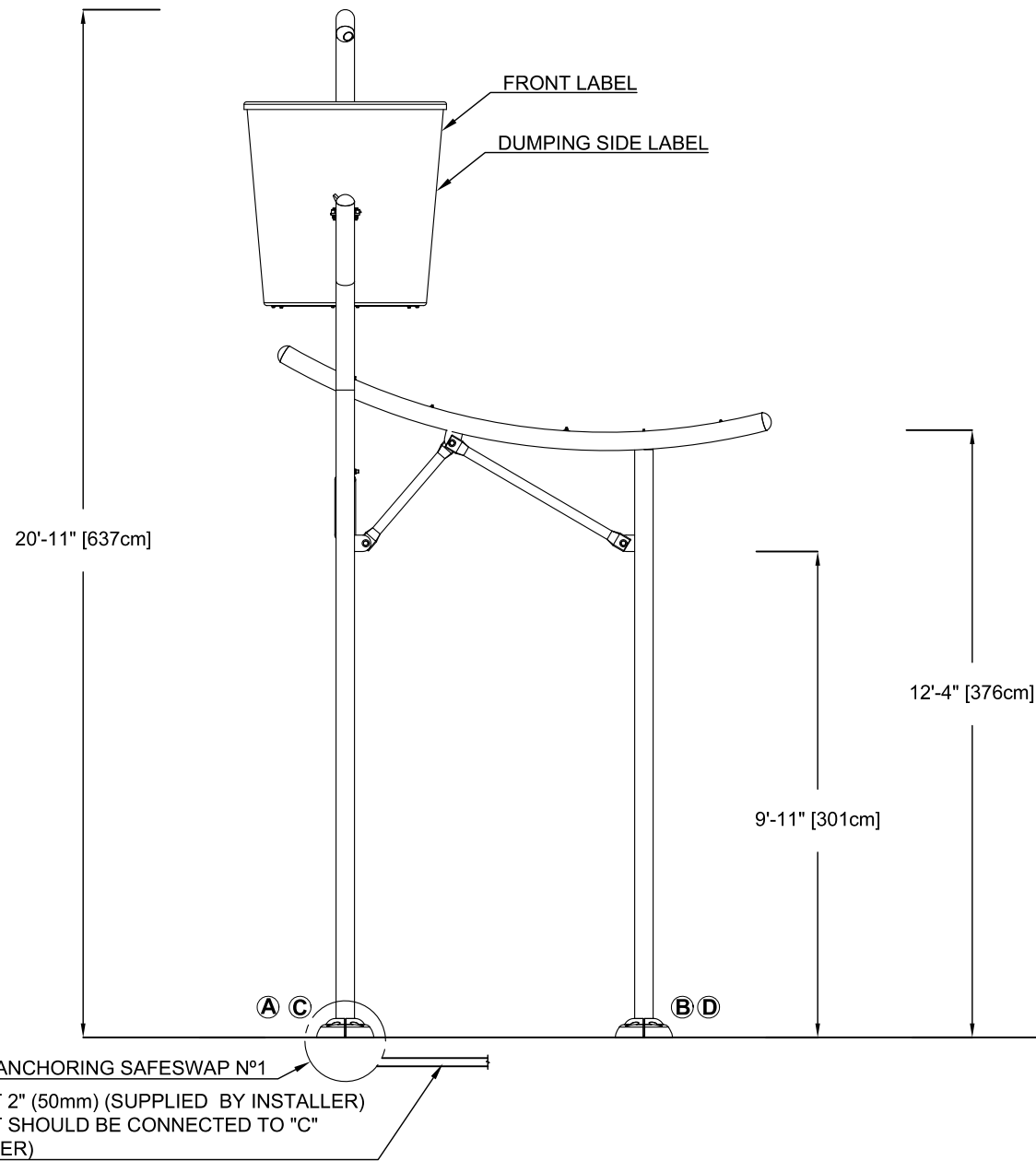

**SIDE ELEVATION VIEW**

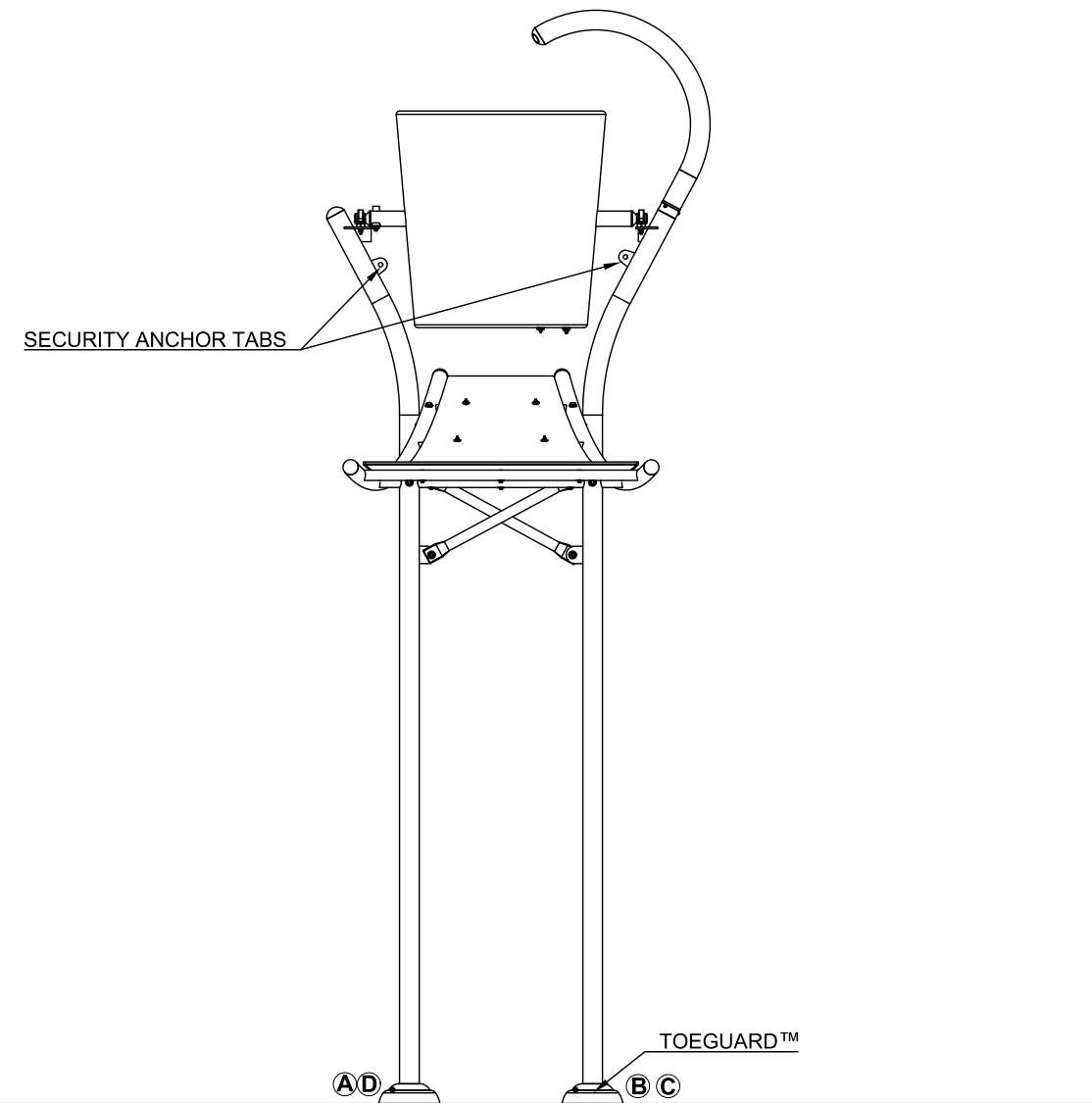

PRODUCT NAME: SUPER SPLASH N°2

PRODUCT NUMBER: VOR-0130.2XXX

**PRODUCT INFORMATION**

DATE: 09/09/24

SHEET NO: 1/1

11"x17" SHEET SIZE

